



MACINTOSH INSTALATION INSTRUCTIONS FOR

## MacWireless 11g AirPort Booster

### For Wireless Device with N-type Connector

Before installing your antenna, we recommend that you test your current signal level using iStumbler. Compare this result to the signal level after installation to see how much your connection has improved. iStumbler is included on the MacWireless CD in the "Extra Software" directory, and is also available for download at: <http://www.istumbler.net/>

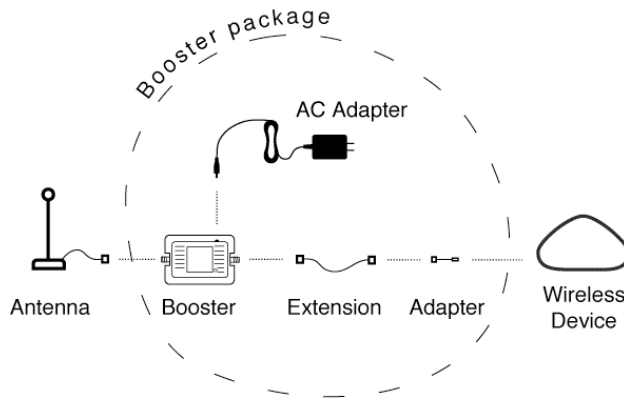

1. Power off your wireless device.
2. If there is an antenna currently attached to the wireless device, remove it.
3. Attach the white MacWireless cable adapter to the gold SMA extension cable. The small white cable adapter may already be attached to the end of the extension cable.
4. Connect the extension cable and adapter to your wireless device.
5. Connect the other end of the extension cable to the booster's radio jack. The jacks are labeled on the bottom of the booster.
6. Connect an antenna to the booster's antenna jack. If you are using a Dr. Bott Antenna, connect the Dr. Bott adapter to the end of the antenna cable before connecting the antenna to the booster.
7. Connect the AC adapter to the booster's DC jack and plug it into an electrical outlet.
8. Power on your wireless device and position the antenna for optimal performance.



**N-type Connector**

## Troubleshooting

### I'm not seeing a significant increase in range. What can I do?

1. Verify the physical connections, and make sure that you power-cycle your wireless device after connecting or disconnecting range extending hardware.
2. Aim the antenna appropriately. For more information on how your antenna radiates energy, see the antenna help section of our website: <http://www.macwireless.com/html/help/antenna.html>

### Factors Affecting Range and Performance of All Wireless LAN Systems

Range estimates are typical and require line of sight. Basically that means you will need a clear unobstructed view of the antenna from the remote point in the link. Keep in mind that walls and obstacles will limit your operating range and could even prevent you from establishing a link. Signals generally will not penetrate metal or concrete walls. Trees and leaves are obstructions to 802.11 frequencies so they will partially or entirely block the signal. Other factors that will reduce range and affect coverage area include metal studs in walls, concrete fiberboard walls, aluminum siding, foil-backed insulation in the walls or under the siding, pipes and electrical wiring, furniture, and sources of interference. The primary source of interference in the home will be the microwave oven. Other sources include other wireless equipment, cordless phones, radio transmitters, and other electrical equipment. Due to the increased gain, installing range extender antennas in the presence of interference could actually yield equal or worse range. These solutions work for the vast majority of our customers. However, due to the numerous factors affecting range and performance, we do not guarantee that you will achieve any specific improvement in range for your specific application.

*This modification may void your warranty. MacWireless accepts no responsibility or liability for any modification. Although MacWireless products have been tested and verified, MacWireless does not accept responsibility for loss or damage to any equipment or device. Use at your own risk.*